

Scharnieren - Charnières

Verzinkt en gepoederlakt in ral 9005.
Galvanisé et thermolaqué en ral 9005.

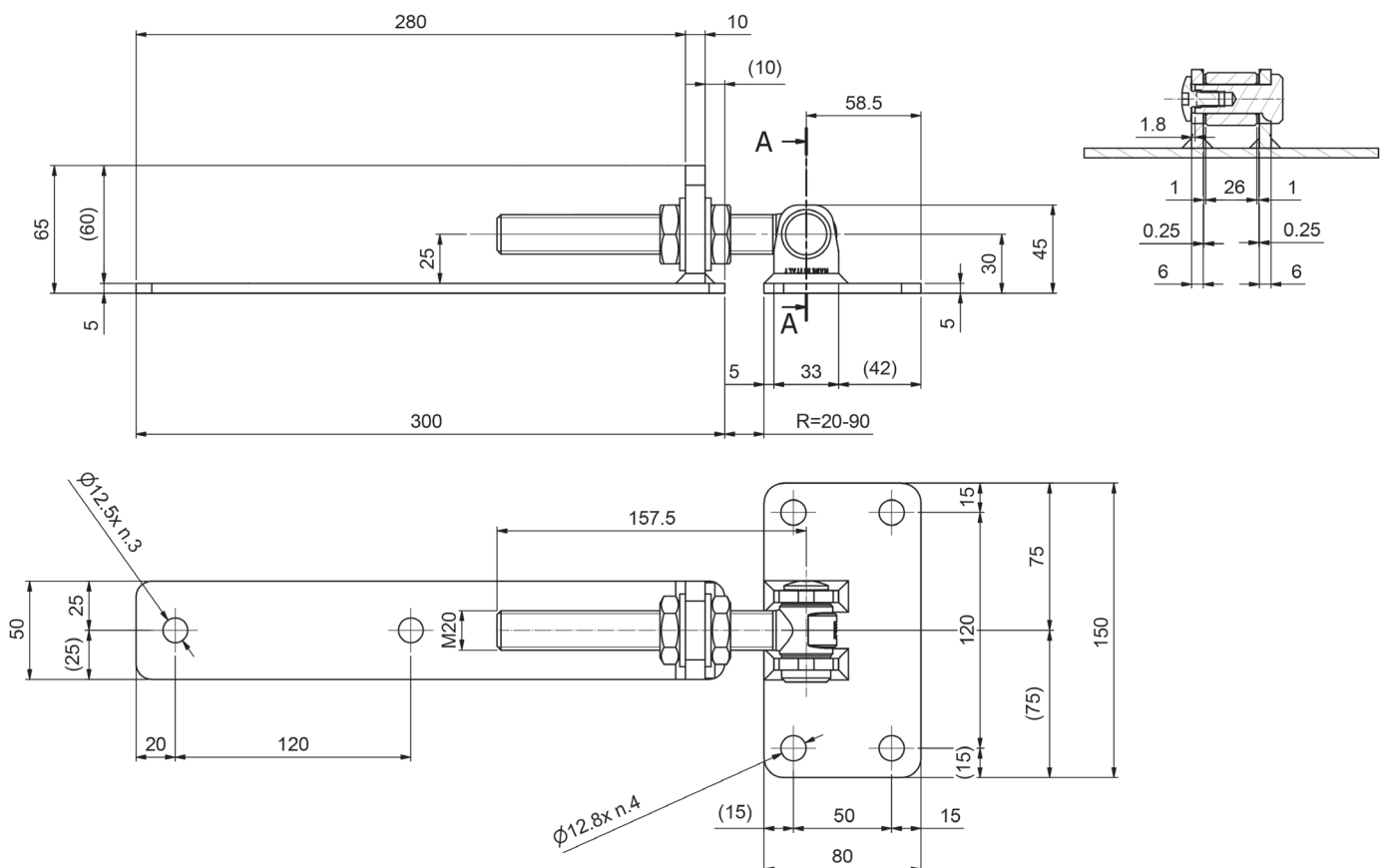

Verzinkt en gepoederlakt in ral 9005.
Galvanisé et thermolaqué en ral 9005.

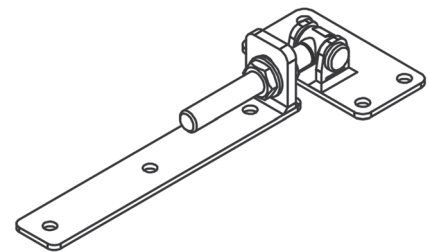
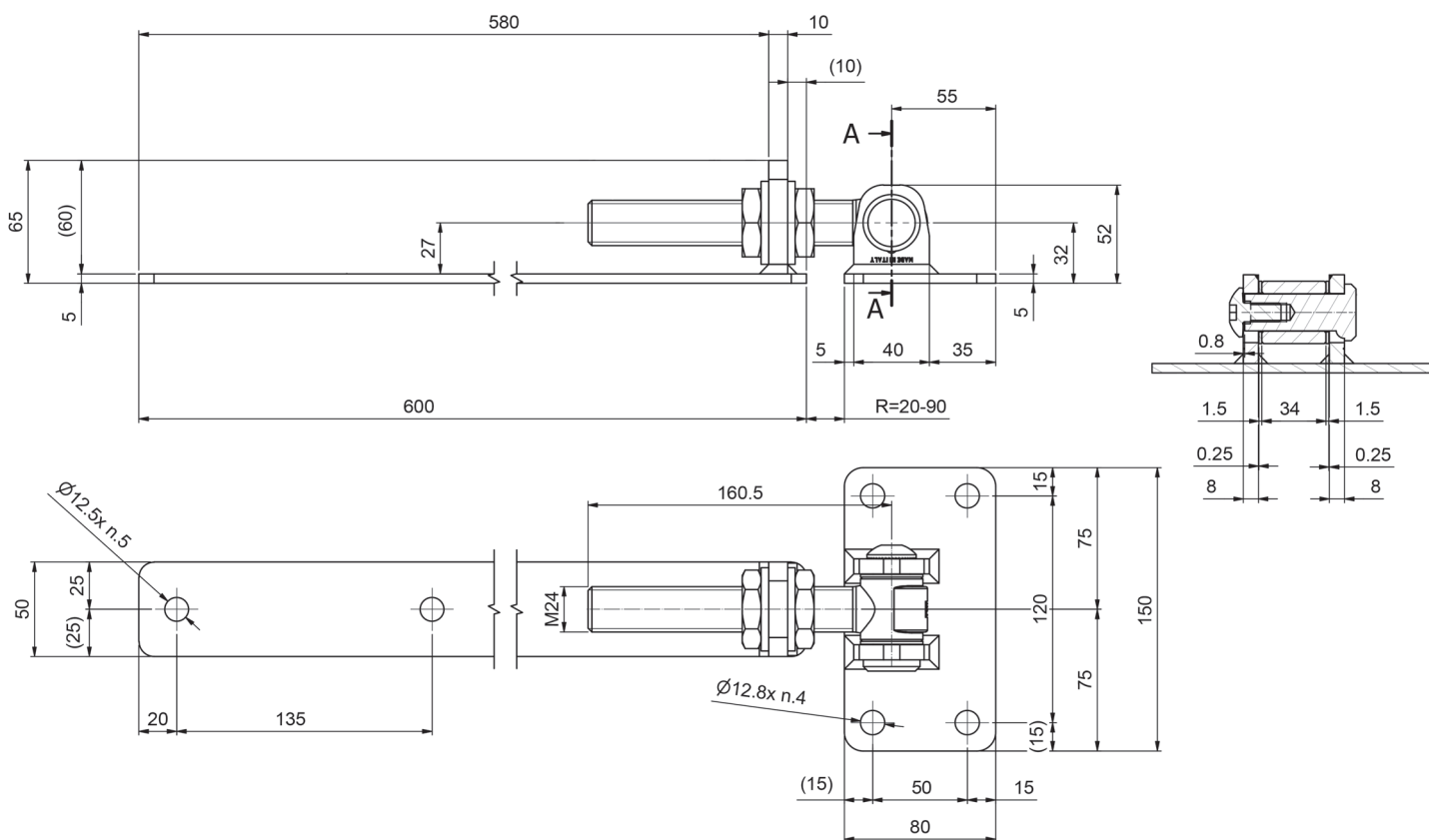
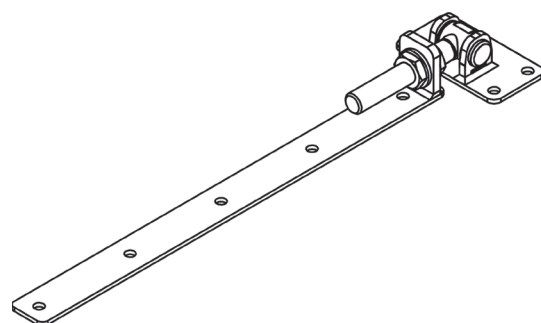
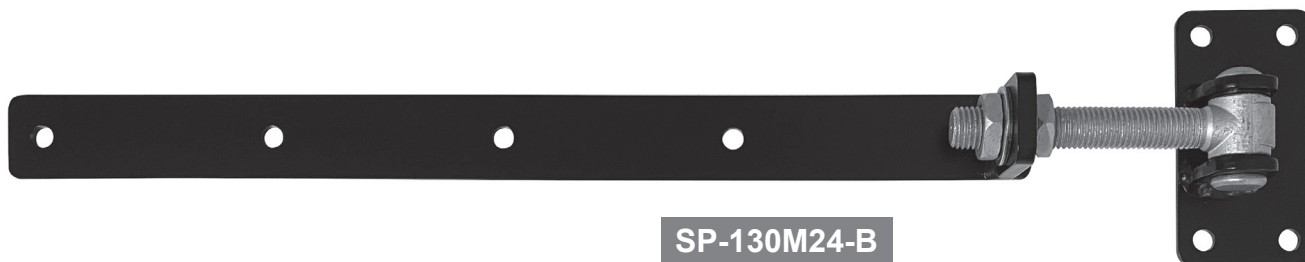

Verzinkt en gepoederlakt in ral 9005.
Galvanisé et thermolaqué en ral 9005.

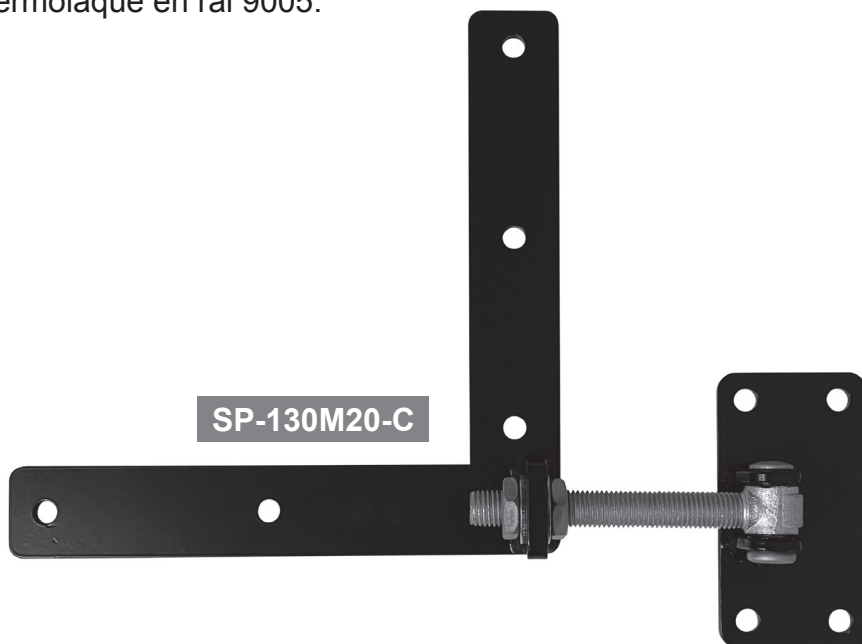

SP-130M20-C

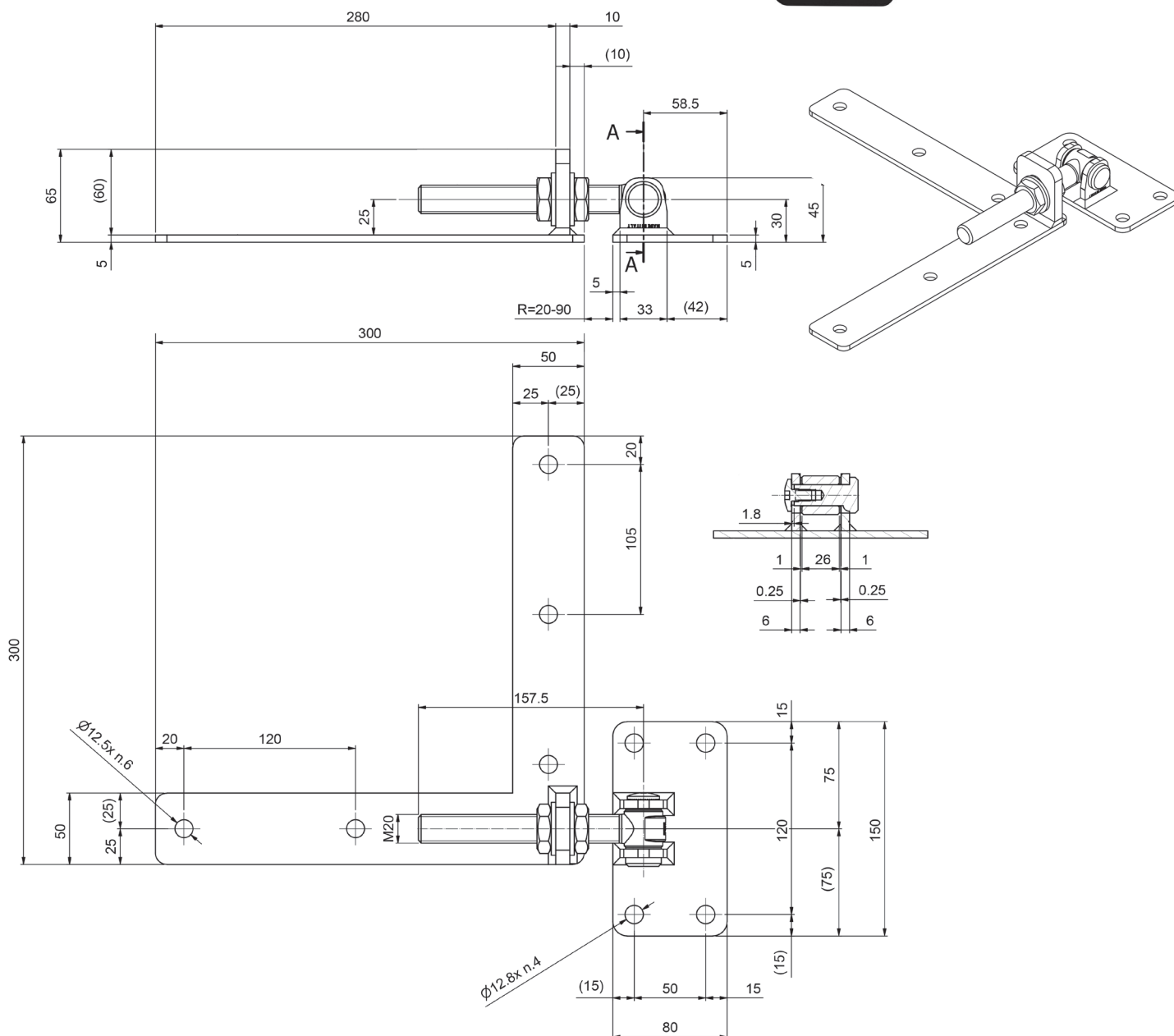

Verzinkt en gepoederlakt in ral 9005.
Galvanisé et thermolaqué en ral 9005.

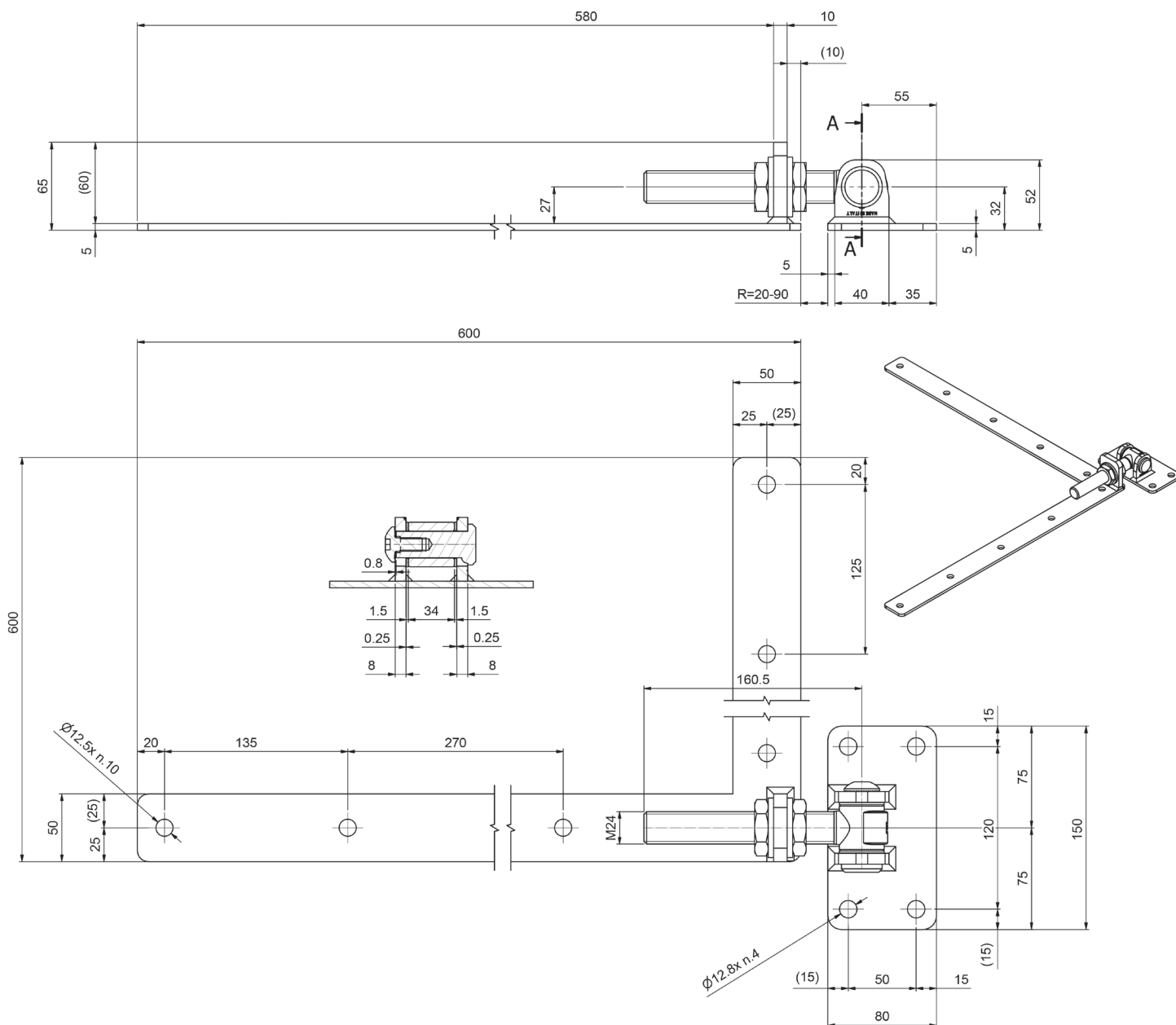
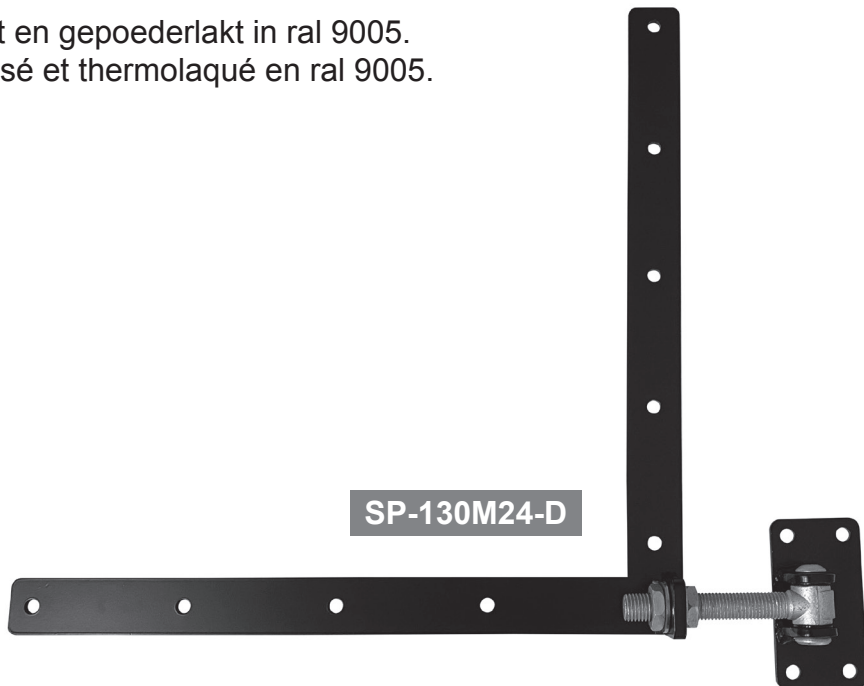

Verzinkt en gepoederlakt in ral 9005.
Galvanisé et thermolaqué en ral 9005.

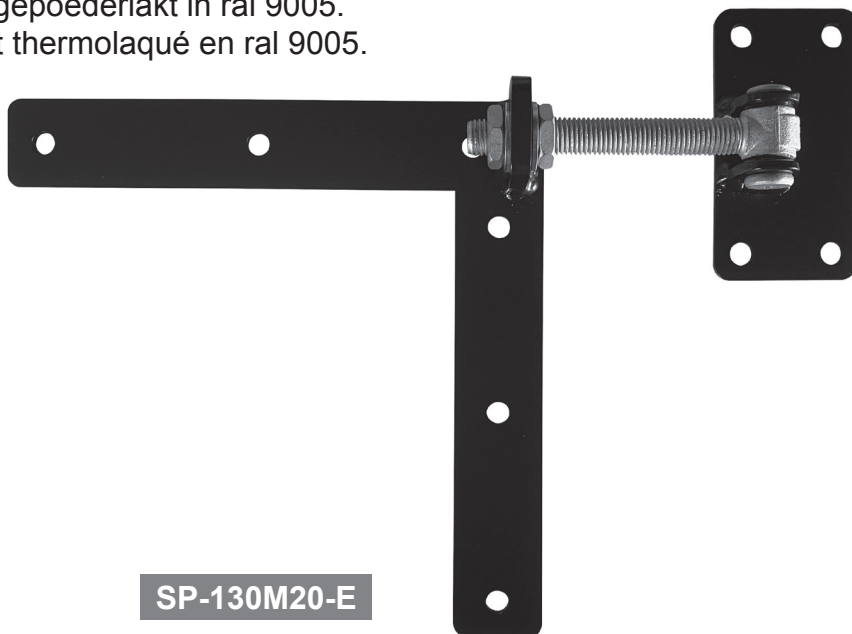

SP-130M20-E

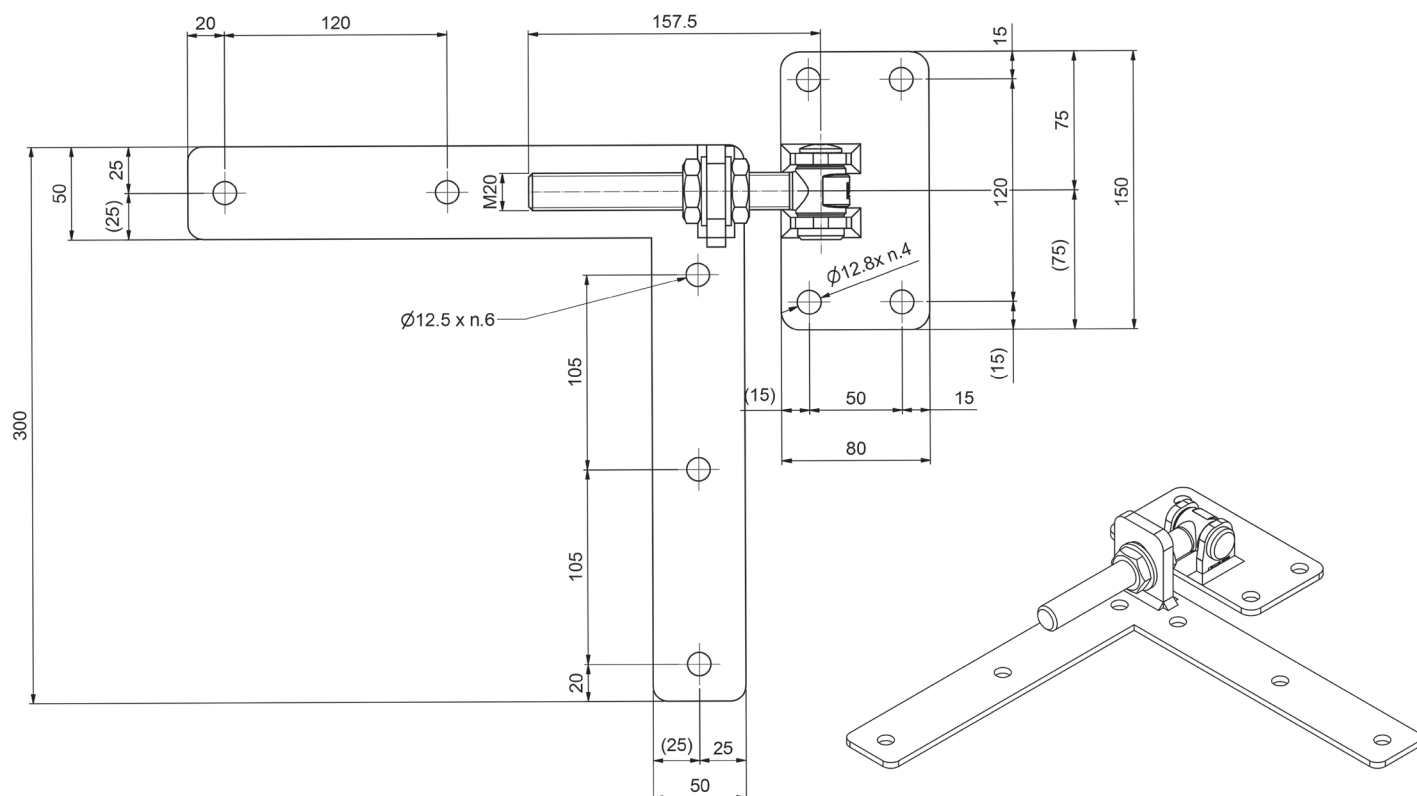
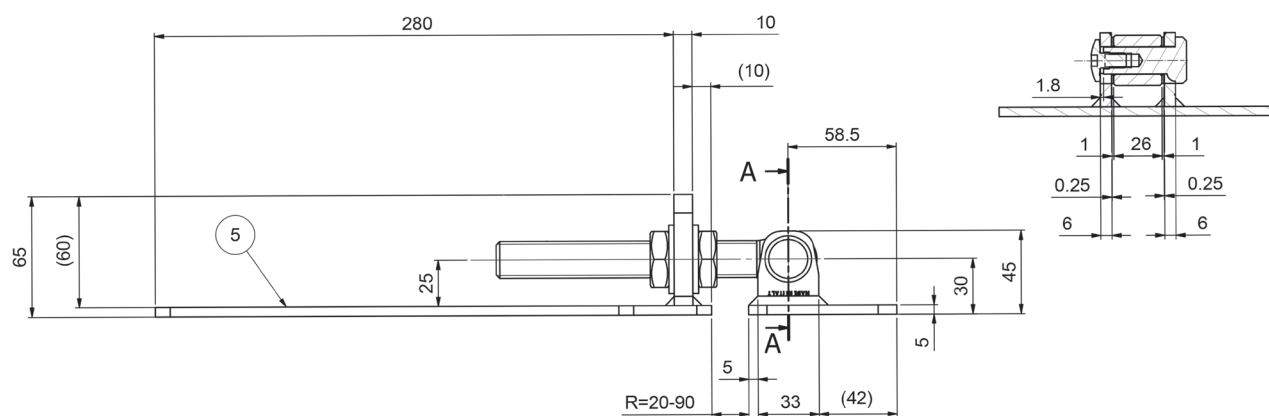

Verzinkt en gepoederlakt in ral 9005.
Galvanisé et thermolaqué en ral 9005.

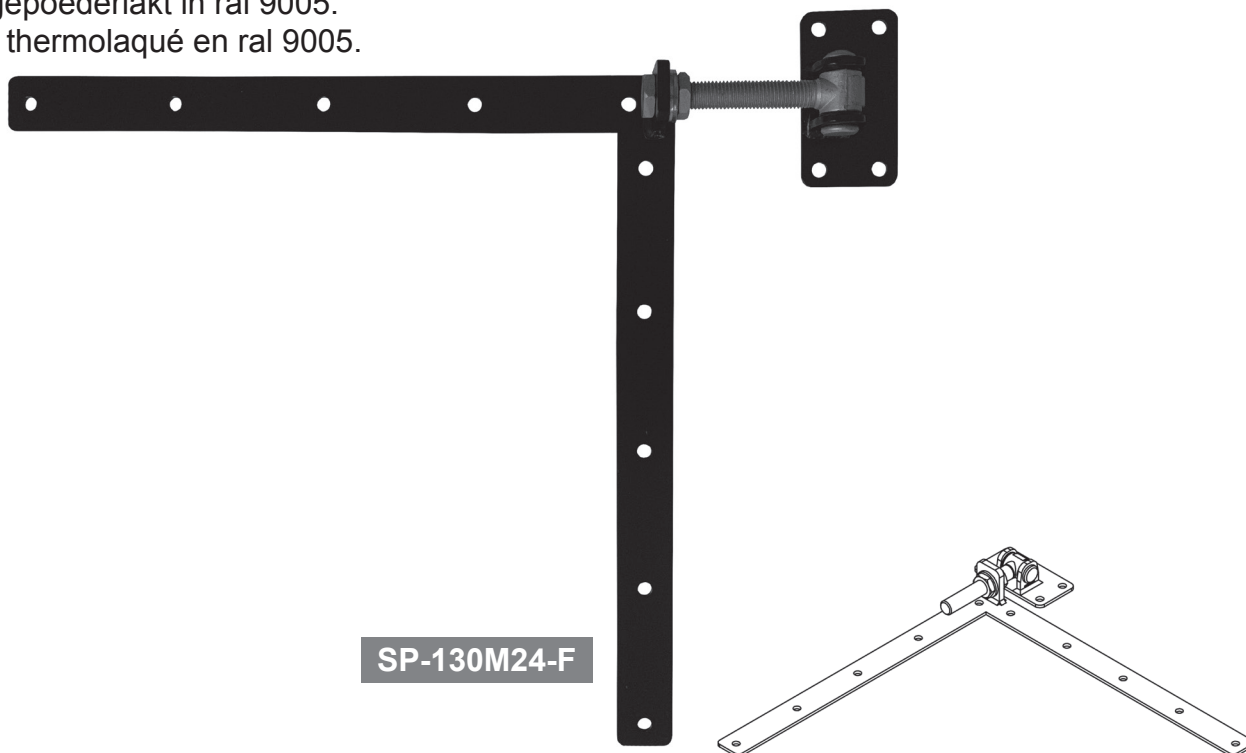

SP-130M24-F

